

GLOBAL SALES NETWORK



Premium Range Electric Pallet Truck



HANGCHA GROUP CO., LTD.
(Zhejiang Hangcha Imp. & Exp.Co.,Ltd.)

www.hcforlift.com

Add:398 Shi Qiao Road, Hangzhou Zhejiang province, China(310022)
 Factory site:No.88, Donghuan Rd., Economic Development Zone Lin'an, Zhejiang, China(311305)
 Tel: +86-571-88926755
 Fax: +86-571-88926789 88132890
 E-mail: sales@hcforlift.com

HANGCHA GROUP CO., LTD. Reserves the right to make any changes without notice concerning colors, equipment, or specifications detailed in this brochure, or to discontinue individual models. The colors of trucks, delivered may differ slightly from those in brochures.

2014 VERSION 2/COPYRIGHT 2013/08

HANGCHA GROUP CO., LTD.

Durability

Durable frame construction, with integrated welded forks brings the truck high rigidity, and long working life. New butterfly drive controller is more easy for operator. Integrated ZF transmission system, more reliable.

Productivity

Compacted chassis design, makes the truck operated in limited spacious. Powerful AC traction motor with Curtis control system. Applied MOSEFET high frequency control. Germany WICKE wheel. Unique steering pivot design, which makes the drive motor suspends during steering. Shock absorber are standard specification for the caster wheel, prolong the truck's working life time.

Ergonomics

Tiller is ergonomically designed for Max. driver's comfort. Dual lift/lower button controls allow operation by either hand. Creep speed control button is available. Conductor belt is standard specification.

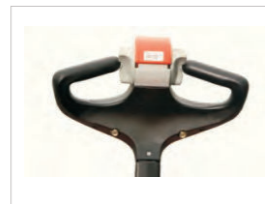
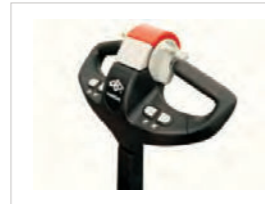

Serviceability

Battery discharge indicator with lifting interrupt as standard specification when 20% battery capacity available and inform the operator of recharge requirement. IP54 environment sealing, which protect the inside components. Open the back cover, every components are easy to reach.

Standard Specifications

- Poly. Drive wheel and load wheels
- AC drive motor and control system
- Emergency cut off switch
- Combined hydraulic unit
- LED panel
- 220Ah battery

Customer options

- 900mm,923mm,973mm,1000mm, 1019mm,1023mm,1125mm fork length
- 520mm,560mm,670mm fork distances
- Tandem load wheel
- High frequency auto charger

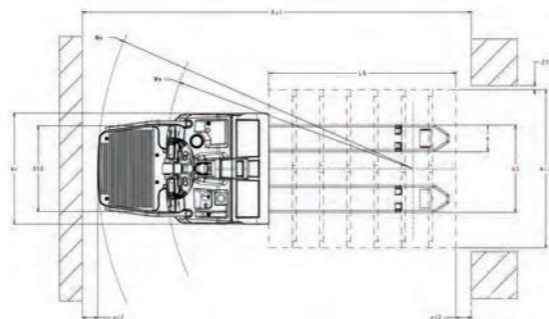
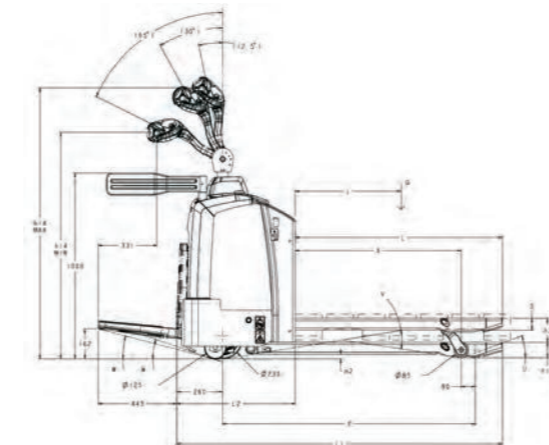

	WHEELBASE TYPE	SINGLE LOAD WHEELS (LONG WHEELBASE)		*TANDEM LOAD WHEELS (SHORT WHEELBASE)		
		560				
		1173	1171	1173	1171	
DISTINGUISHING MARKS	1.1 MANUFACTURER	HANGCHA				
	1.2 MANUFACTURER'S TYPE DESIGNATION	CBD20-TC1		CBD20-TSC1		
	1.3 DRIVE	ELECTRIC				
	1.4 OPERATOR TYPE	PEDESTRIAN		PEDESTRIAN/PLATFORM		
	1.5 LOAD CAPACITY/RATED LOAD	Q (t)	2.0t			
	1.6 LOAD CENTER DISTANCE	c(mm)	587	586	587	586
	1.8 LOAD DISTANCE	x(mm)	942	893	942	893
	1.9 WHEELBASE (RAISED)	y(mm)	1352	1304	1351	1304
	TIRES, CHASSIS	3.1 TIRES	POLY			
3.2 TIRE SIZE, FRONT		Φ250×100				
3.3 TIRE SIZE, REAR		Φ85*110	Φ85*95	Φ85*110	Φ85*95	
3.4 ADDITIONAL WHEELS (CASTERS)		Φ100*40		Φ125*50		
3.5 WHEEL NUMBER FRONT/REAR(X=DRIVE WHEELS)		1*+2/2	1*+2/4	1*+2/2	1*+2/4	
3.6 TREAD, FRONT		b10(mm)	461			
3.7 TREAD, REAR	b11(mm)	390				
DIMENSIONS	4.4 LIFT	h3(mm)	130			
	4.9 HEIGHT OF TILLER IN DRIVE POSITION MIN/MAX	h14(mm)	829/1288		1219/1459	
	4.15 HEIGHT, LOWERED	h13(mm)	83			
	4.19 OVERALL LENGTH	L1(mm)	1751	1749	1844/2289	1842/2287
	4.20 LENGTH TO FACE OF FORKS	L2(mm)	578		671	
	4.21 OVERALL WIDTH	b1(mm)	712			
	4.22 FORK DIMENSIONS	s/e/L(mm)	64*170*1173	64*170*1171	64*170*1173	64*170*1171
	4.25 DISTANCE BETWEEN FORK-ARMS	b5(mm)	560			
	4.32 GROUND CLEARANCE, CENTER OF WHEELBASE	m2(mm)	21			
	4.33 AISLE WIDTH FOR PALLETS 1000×1200 (TRANSVERSE)	Ast (mm)	1980	1979	2050/2488	2050/2488
	4.34 AISLE WIDTH FOR PALLETS 800×1200 (LENGTH)	Ast(mm)	2007	2008	2077/2515	2079/2517
4.35 TURNING RADIUS	Wa(mm)	1549	1501	1619/2057	1572/2010	
PERFORMANCE DATA	5.1 TRAVEL SPEED, LADEN/UNLADEN	km/h	6.0/6.0		(6.0/6.0)/(8.0/8.0)	
	5.2 LIFT SPEED, LADEN/UNLADEN	m/s	0.04/0.05			
	5.3 LOWERING SPEED, LADEN/UNLADEN	m/s	0.09/0.04			
	GRADEABILITY, LADEN/UNLADEN	%	10.0/15			
	5.7 GRADEABILITY (PEDESTRIAN)	U/V/W(%)	34/15/38	34/16/38	34/15/29	34/16/29
	GRADEABILITY (PLATFORM)	U/V/W(%)	-	-	34/15/24	34/16/24
	5.8 MAX. GRADEABILITY, LADEN/UNLADEN	%	14.5/20			
5.10 SERVICE BRAKE		ELECTRIC				
ELECTRIC-ENGINE	6.1 DRIVE MOTOR RATING S2 60MIN	kw	1.25		1.7	
	6.2 LIFT MOTOR RATING AT S3 15%	kw	1.2			
	6.3 BATTERY ACC. TO DIN 43 531/35/36 A,B,C,NO	CIRCUIT	B			
	6.4 MAX. BATTERY SIZE	L×W×H(mm)	212×624×627		283×624×627	
	6.5 BATTERY VOLTAGE, NOMINAL CAPACITY K5	V/Ah	24/220		24×330	
	6.6 BATTERY WEIGHT (±5%)	kg	212		312	
ADDITIONAL DATA	8.4 ENERGY CONSUMPTION ACC. TO VDI CYCLE	kwh/h	0.384		0.43	
	8.4 SOUND LEVEL AT THE DRIVE'S EAR ACCORDING TO DIN 12 053	dB(A)	< 70			

■ Specifications are subject to change without notice.
* Optional

